



9kW and 9.6kW Remote Variable Heater Controller (Receiver)

901344C

901345

Unit 9, Stort Valley Industrial Estate
Stansted Road, Bishop's Stortford
Hertfordshire, United Kingdom
CM23 2TU

Available at
www.shadowindustrial.co.uk
01279 466500
info@shadowindustrial.co.uk

Important Information

Please carefully read all instructions provided before using this appliance. The controller must be installed and used as instructed.

This Operation Manual contains the important safety information, as well as some recommendations on correct use, installation and maintenance of the appliance.

When operating the controller observe necessary safety precautions, as improper use may result in injury or damage to property.

Ensure to keep this manual along with your sales receipt, and if possible, cardboard package and packing material in case return of the unit is necessary.

- Unpack the controller making sure that all the items are present
- Using the detailed images follow the steps to assemble your controller.
- Do NOT connect the controller to the power supply until the assembly is complete.
- Do NOT connect the controller to the power supply if any of the components are damaged in any way.

Safety Instructions

Read these instructions before using.

WARNING

Potential fire risk if the controller is covered by any flammable materials.

- Ensure that the controller's vents and cooling fans are clean and free from obstructions to prevent overheating.
- Do NOT use in unventilated areas.
- Do NOT use where gas, petrol, paint or other flammable materials are stored.
- Always wait till the controller has cooled down completely before putting into storage.
- Improper use of the appliance can result in electric shock or fire hazard.
- If the controller malfunctions or behaves abnormally, disconnect power and seek professional assistance for troubleshooting and repair.
- Ensure that operators are aware of the potential hazards associated with the controller and are trained in its safe operation and emergency procedures.
- The unit needs to be isolated from the power and sufficiently cooled before cleaning.
- Do NOT immerse the controller into water when cleaning.

Cleaning and Maintenance

- Isolate the appliance from the power supply system.
- After the appliance has cooled down, the housing can be wiped clean with a damp cloth.
- Wipe the appliance only with a clean and lint-free cloth or a soft brush.
- Do NOT use any abrasive or hard cleaning products on any part of the controller.
- Wait until the unit is completely dry before use.

Regularly inspect the controller for any signs of damage, wear, or loose connections. If any issues are identified, disconnect power and contact a qualified technician for repair or replacement.

Assembly Instructions

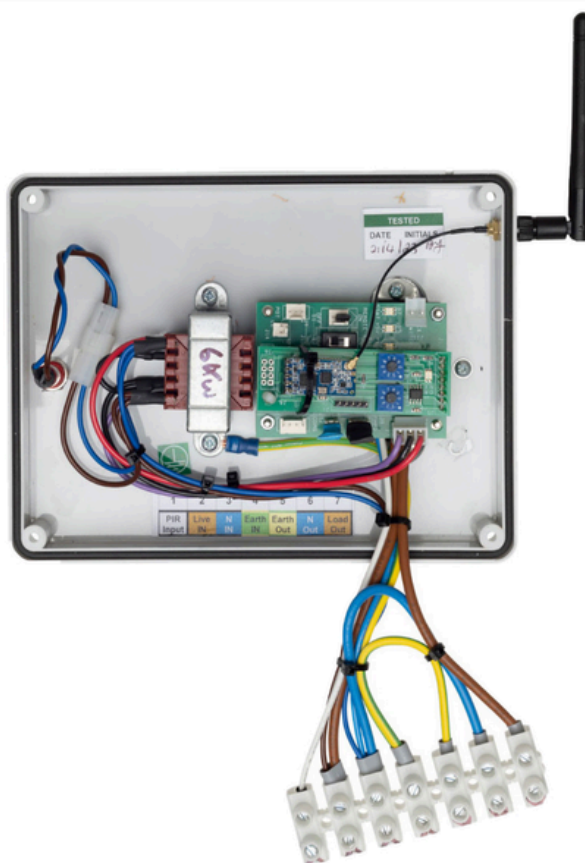

1. Isolate the Mains before removing the cover. Remove the cover by removing the 4 screws. There is a terminal strip connector for connecting the Mains IN and Mains OUT.
2. Use the three cable glands to bring the Mains cables into and out of the controller base .
3. Connect Mains IN - Live brown (2), Neutral blue (3) and Earth green/yellow (4) wires to terminals marked Live IN (2), N IN (3) and Earth IN (4).
4. Connect the Infrared Heater - the brown Live wire to Load Out (7), the blue Neutral wire to N Out (6) and the green/yellow Earth wire to Earth Out (5) .
5. The trigger from a motion detector (PIR) QHPIR is connected to the terminal PIR Input (1) .
6. When all connections are complete and connected correctly, check once again that the wiring is correct as per steps above - 3 & 4 . Then replace the cover and tighten the fixing screws.
7. Turn ON or reconnect the Main Power to the controller . The red neon lamp on the LHS will illuminate to indicate that the unit is LIVE .

The controller is now ready to be controlled by the wireless remote unit QHVCR . See instructions for QHVCR operation, page 7 follow steps 8 to 14 .

Only a qualified electrician should install this device. For use use with our controllers, we recommend using only:

D32 MCB

QHVCr Master Controller (Transmitter)



Freq. Setting
0-9



Zone Setting
1,2 and 3

Receiver Board

8. There are three control dials Blue, Yellow & Red one for each zone. The QHCxxMR units are preset to operate in one of these zones. The QHCxxMR unit once preset will only operate in that designated zone. The factory setting is 1, which is the Blue control dial.
9. Turn ON the QHVCR unit by pressing the ON/Standby button on the front panel. The Led indicator will flash orange - green - orange - green and remain Green to indicate that the unit is ready.
10. The QHCxxMR unit is preset as a Blue zone (1). Turn the Blue control dial to position 2. The heaters connected to the QHCxxMR units will come ON at the minimum setting 33%. Continue to turn the Blue control dial through positions 3 to 5 until you reach the desired setting. Settings are 1 = 0%, 2 = 33%, 3 = 50%, 4 = 66% & 5 = 100%.
11. QHCxxMR units which are preset to Yellow & Red zones are controlled by the Yellow & Red control dials respectively and will operate as above.
12. The QHVCR unit is powered by 3 x AAA batteries. The unit will automatically go into standby mode if the unit is inactive for more than 30 seconds. When the unit goes into standby mode all the QHCxxMR units will remain unchanged at the settings they were set at. Therefore the heaters will remain ON.
13. To change a setting just press the ON/Standby button and proceed as described in 2) & 3). However, while the QHVCR unit is ON, you can turn OFF all the heaters by pressing the ON/Standby button. This is indicated by the Led indicator flashing Red.
14. The previous settings will be remembered and will be restored when you press the ON/Standby button again.

Please note: The QHVCR remote Master Controller can control any number of QHCxxMR controllers as long as they are within range, up to 100 meters* (see specification sheet for the QHVCR unit). The QHVCR should be wall mounted. *Longer antennae are available to extend the range up to 200 meters.

Pairing Programming Devices QHVCR & QHCxxMR

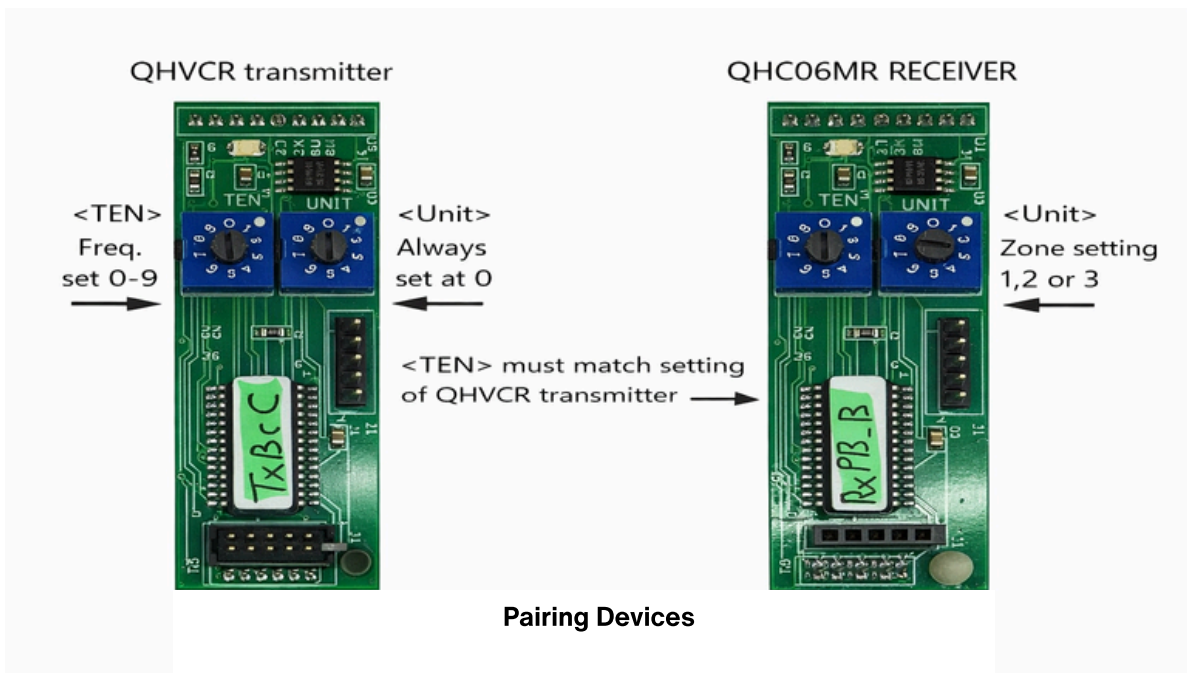

1. The Left Hand Side rotary switches (TEN) on both boards must be set the same. The RF frequency setting must match on both boards. There are 10 possible frequencies that can be selected from 0-9. If the settings on the LHS switch (TEN) do not match the devices will fail to operate.

When designating the transmitter and receiver, ensure both the left rotary switches are set at 0, this ensures that the transmitter marked 0 will communicate with the receiver marked 0. Set the left rotary switch to 1, so the transmitter marked 1 will communicate with a receiver also marked 1.

If the transmitter and receiver are not paired correctly they will not communicate and therefore will not operate. A transmitter marked 0 will not communicate with a receiver marked 1.

The transmitter and receiver must be set to the same number for them to communicate.

2. The Right Hand Side rotary switches (UNIT) are for setting the device to operate in a set zone. There are 3 possible zones that the controller can be set to: Blue Zone for 1, Yellow Zone for 2, and Red Zone for 3.

Note: QHCxxMR = QHC06MR, QHC18MR, or QHC24MR

PIR Motion Detectors connection & Operation

PIR motion detectors are passive infrared sensors and electronic devices that are triggered by infrared light from the movement of objects in their field of view.

We recommend the QHPIR is used with our QHC controllers. Connecting the PIR to the QHCxxMR will enable the controller to turn ON only once the presence of a person is detected by the PIR.

The angle of the PIR and the viewing width of the lens needs to be adjusted to ensure you target the desired detection area. Full lens width will have a large detection area. For smaller area, the lens narrows the lens using the lens mask.

Setting the Lens width correctly is crucial, if it's set incorrectly the PIR could be continuously be ON, causing the heaters to remain ON too.

Connect the switched trigger to terminal #1 PIR Input on the QHC06MR controller.

The switched Live OUT to the QHC06MR controller is a Live 240V feed, this is only used as a signal Input to the controller.

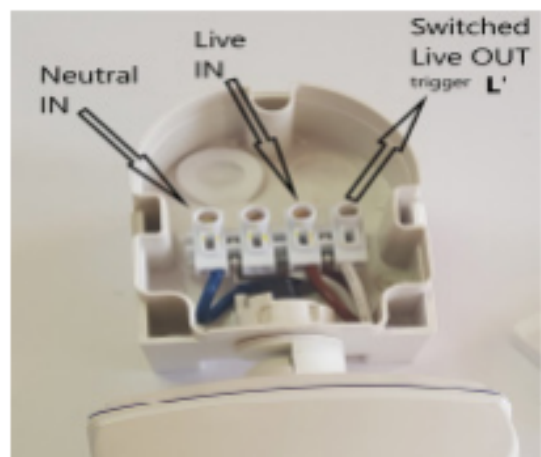
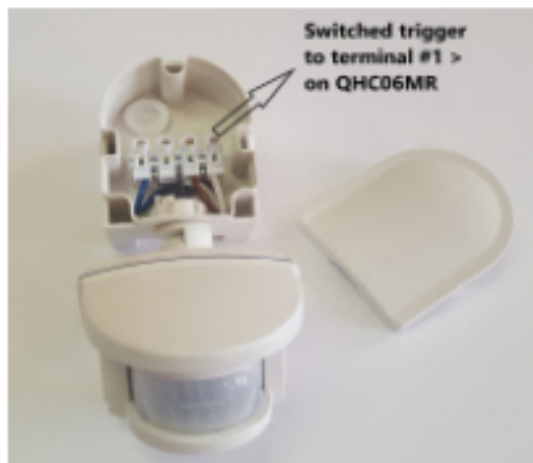

7-Day Programmable Timer Fitting Option

A 7-Day programmable timer can be fitted as an option instead of the PIR. It is important to note that only one or the other can be fitted to the QHCxxMR controller, not both.

S1 & S2 are found on the printed circuit board (PCB) QHPCB-A, See Fig 12.

Default Settings for S1 & S2

Remote OFF - S1. Jumper is factory set to the OFF position pins 2 & 3. For Manual operation, PIR & 7-Day Timer OFF - S2. Slide switch is factory set to the OFF position 2, see Fig 12.

Setting Up a 7-Day Programmable Timer

The S2 Slide switch must be set to the ON position 1

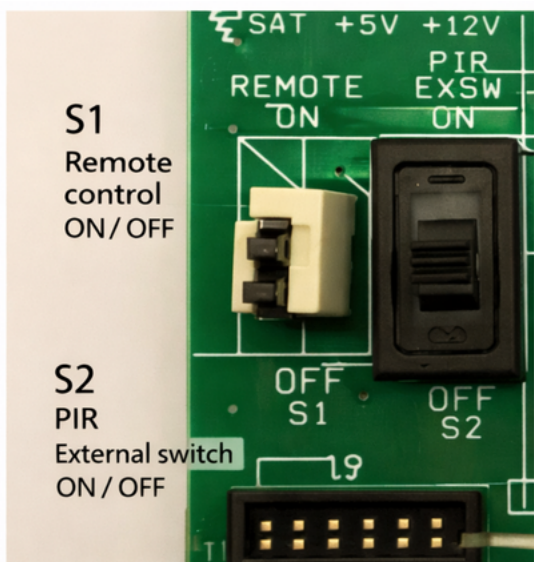
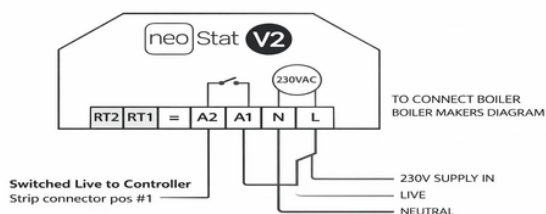

Fig 12, Slide switch S2 is in the OFF position.



Fig 13, a typical 7-Day Programmable Timer



This product must only be installed by a qualified electrician and comply with local installation regulations.

Fig 14, wiring connection to the QHCxxM & MR controller

The switched Live through A2 terminal on the 7-Day timer is connected to terminals #15, 16 & 17 on DIN Rail connections of the QHCxxM & MR controller. A Jumper Link must be fitted to terminals #15, 16 & 17 so that the three outputs will operate together as one.

Once the 7-Day programmable timer is fitted correctly it will now control when the controller will be ON or OFF, see Fig 14. This function can be disabled by simply switching the S2 slide switch back to the OFF position 2, see Fig 12.

Expandable Heating System

Using a QHVCR & Multiple QHC03MR, QHC06MR & QHC09MR Controllers

Using the remote 3-zone QHVCR controller the area being heated can be zoned into three area's Blue, Yellow & Red. Each zone can be controlled separately, this includes setting each zone at a different level.

The 5 setting levels are > Off - 1 (33%) - 2 (50%) - 3 (66%) - 4 (100%).

Any QHC controller can be used in the proposed zoned layout below. The controllers available are 3kW QHC03MR, 6kW QHC06MR & 18kW QHC18MR which can be used depending on the overall number of heaters required.

Troubleshooting

1. The QHCxxMR (receiver) is not working:

Check that the unit is wired correctly and follow the installation procedure on page 6. The neon indicator should be ON to indicate that the Mains are connected correctly. Then check that the status LED D5, the +5v LED D6 & the +12v LED D7 are all ON green. If the status LED is Red, this indicates that there is a problem with the mains connection to the board. If the +5v or +12v LEDs are Red this indicates that there is a problem with the processor chip or a power supply problem.

2. There is no communication between the QHCxxMR & QHVCR:

This means the units may not be paired correctly. First, determine what frequency the QHVCR is set at. The setting is marked at the back of the unit. If it's marked (0) you must check to see if the QHCxxMR is also set the same and is also marked (0). If they are different then the controller QHCxxMR will not work. If needed you can reset the controller QHC06MR by following the Pairing instructions on page 9.

3. Paired transmitter QHVCR & receiver QHCxxMR won't communicate even when they are both set the same:

The small antenna RF PCB could be the problem. Check if the small LED flashes Red when the transmitter QHVCR is turned ON & OFF. If the LED flashes Red, it means the communication between the two devices is good. Otherwise, if the LED remains ON Green then the RF PCB is faulty and needs to be replaced.

However, if the RF PCB is working and the LED flashes Red but the controller QHCxxMR is still not working, the cable connection between the RF PCB and the Antenna could be faulty and may need to be replaced

4. The yellow zone is not working:

The problem could be the receiver is set as a blue zone or red zone. If this is the case all you have to do is re-set the right-hand rotary switch to position 2.

5. The circuit Breaker MCB keeps tripping when the heaters are turned ON:

Ensure that the MCB is a Type D where there are likely to be surges. A common fault is using Type B or C circuit breakers instead but this will always fail. We recommend either:
RCBO :Hager AD982J C32 Double module
MCB :Hager MU132A C32 Single module

6. The controller does not respond to settings 3 & 4:

Check for a loose or missing Black connector ref. J8 (TMP2) header on the printed circuit board (PCB).

Technical Data

Supply voltage: Single Phase 240V AC 50 Hz

Max. Load capacity: 9 kilo Watts and 9.6kW (QHC09MR).

Over Temperature Protection: On each O/P - LED indicators 1,2 & 3

Input	Live (Brown)	Terminal 2
	Neutral (Blue)	Terminal 3
	Earth In (Green/Yellow)	Terminal 4
Input	PIR Input Trigger	Terminal 1
Output	Switched Live out (Brown)	Terminal 7
Soft Start	Neutral Return Out (Blue)	Terminal 6
	Earth Out (Green/Yellow)	Terminal 5
Transmission	RF	433mHz
Range	Short Antenna	40 meters *(line of sight)
	Long Antenna	100 meters *(line of sight)
IP Rating:	IP53	
Dimensions:	200mm x 180mm x 120mm	
Weight	1.5kg	